

**Inoxia - stainless steel fronts**

Unusual, front coated with stainless steel.

- Thickness approx. 20 mm
- front coated with stainless steel 1 mm
- Two different versions
- Inoxia - Edges with 4 corners
- Inoxia Maniglia45 - 1 edge bevelled by 45 degrees
- Neatly welded corners
- Backside made of chipboard with grey melamine resin, with ABS edges
- Delivered with a protective foil
- Manufactured to size
- holes for fitting the handles 5 mm (drilled only for stainless steel)
- Weight approx. 19 kg/m<sup>2</sup>
- Lead time approx. 7 weeks

**i Mesures min./max.:**

- height: min. 114 mm / max. 1400 mm
- width: min. 95 mm / max. 1400 mm

	model	finish	surface	backside
<a href="#">57.18000.00</a>	Inoxia	stainless steel	SAT	chipboard
<a href="#">57.18100.00</a>	Inoxia Maniglia45	stainless steel	SAT	chipboard

**! Grain direction / angle**

- The grain direction in the SAT surface is vertical! If you need a front with a horizontal cut, the maximum height is 1400 mm
- The bevelled unit Inoxia Maniglia45 can be either at the side, top or bottom.

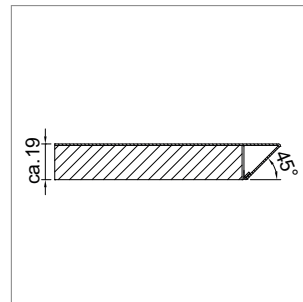
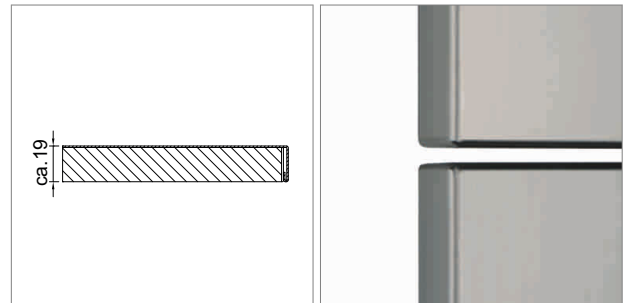

- SAT Inox scotch brite

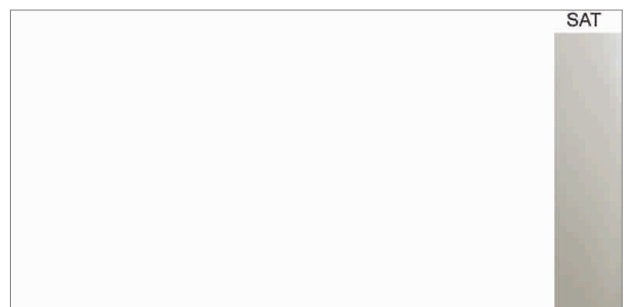
**i Note for order per fax:**

You find decor end panels on page B-1.23, samples on page B-1.26. For fax orders and enquiries: order form on page B-1.79.

**! Color Charts**

Deviations between colours and the fronts are unavoidable.